

Electrical Characteristics

Module Type	NB-120-MM	NB-125-MM	NB-130-MM
	STC	STC	STC
Maximum Power at STC (Pmp)	120	125	130
Open Circuit Voltage (Voc)	23.80	24.00	24.2
Short Circuit Current (Isc)	6.30	6.51	6.71
Maximum Power Voltage (Vmp)	20.30	20.40	20.5
Maximum Power Current (Imp)	5.91	6.12	6.34
Module Efficiency at STC(η_m)	20.04	20.31	20.59
Power Tolerance	(0, +3%)		
Maximum System Voltage	1000V DC		
Maximum Series Fuse Rating	15 A		

STC: Irradiance 1000 W/m² module temperature 25°C AM=1.5
Power measurement tolerance: +/-3%

Temperature Characteristics

Pmax Temperature Coefficient	-0.35 %/°C
Voc Temperature Coefficient	-0.27 %/°C
Isc Temperature Coefficient	+0.05 %/°C
Operating Temperature	-40~+85 °C
Nominal Operating Cell Temperature (NOCT)	45 ± 2 °C

Mechanical Specifications

External Dimensions	1030 x 680 x 30 mm
Weight	7 kg
Solar Cells	PERC Mono (35 pcs)
Front Glass	3.2 mm AR coating tempered glass, low iron
Frame	Anodized aluminum alloy
Junction Box	IP68,3 diodes
Output Cables	4.0 mm ² , 900mm(+)/900mm(-) or Customized Length
Mechanical Load	Front side 5400Pa / Rear side 2400Pa

Packing Configuration

	1030 x 680x 30 mm	
Container	20'GP	40'HQ
Pieces per Carton	2	2
Pieces per Container	1246	2832

* For details, please consul NABAI.

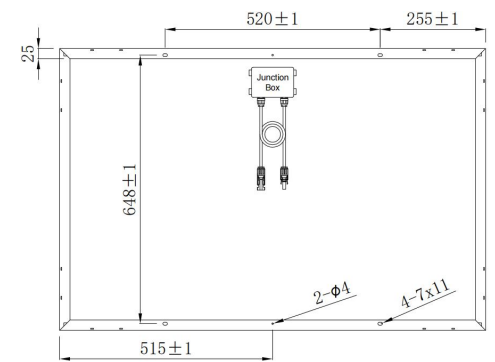
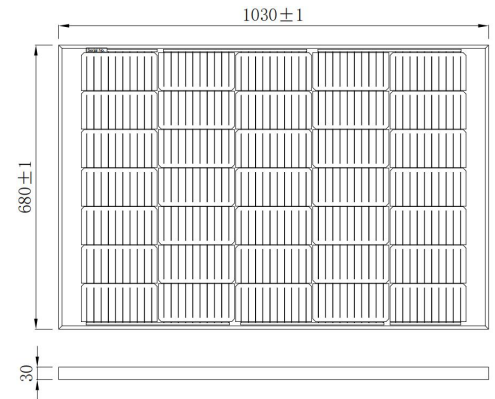

I-V Curve

